Making a drama theatre suitable for a temporary opera production with the orchestra out of the pit by using both architectural and electro-acoustical means

ing. Cees Mulder, dr. Eckhard Kahle
Kahle Acoustics
Molièrelaan 188
B-1050 Brussels
Belgium
cmulder@kahle.be, ekahle@kahle.be

Abstract

In the French city of Toulouse an opera production had to be transferred to a drama theatre. Due to the insufficient size of the orchestra pit, the orchestra was placed on the backstage on a four meter high plateau. In order to create sufficient support to the front stage and the hall, specifically designed sound reflectors were hung above the orchestra as well as in the fly-tower to cross the stage. As the acoustics of the hall was significantly too dry for opera and the sound level of the orchestra was expected to be too low in the hall with respect to the soloist, multiple channel amplification was added to increase the orchestra sound level as well as to create negative absorption to increase reverberation time and level in the hall. This implied an adapted tuning procedure for the system to maintain tonal balance. Furthermore, experiments were carried out to increase spaciousness by increasing signal delay and to increase reverberation time by using loudspeakers in coupled rooms. The project showed that placing an orchestra out of the pit and at an unusual location can be made to work with adequate architectural acoustic and electro-acoustic means. The final acoustic result was perceived as if no amplification was involved, showing that a drama theatre can be made to sound like an opera house.

1. Introduction

Due to the renovation of the “Capitole de Toulouse” in the season 2009/2010, opera productions had to be staged in other locations in the city of Toulouse. One of those productions was the combined production of Schönberg's “Erwartung” and “Pierrot Lunaire” and Poulenc's “La Voix Humaine”. This production was moved to the “Théâtre National de Toulouse” (TNT), a drama theatre. This had been done before with the opera production “La Vie Parisienne”, but the acoustic result (with a small orchestra in the pit) was considered catastrophic. As for the Schönberg/Poulenc production the orchestra pit at TNT was too small to accommodate the required 80 musicians, it was decided to locate the orchestra at the backstage on a plateau four meters above the stage floor. As the sound from the orchestra had to cross the stage and was confronted with the acoustic absorption of the fly-tower and the absence of a ceiling, provisions had to be taken to support the sound from the orchestra. Furthermore, the acoustics of the hall was designed for drama theatre and consequently was acoustically too dry for opera. Also for this situation additional provisions had to be taken.

2. Scenic situation

For two performances the orchestra was required; “Pierrot Lunaire” was performed with a small ensemble located at the left front corner of the stage. For both “Erwartung” and “La Voix Humaine”, large elements were located on the stage that were moved around by dancers as part of the scenery. This meant that if the orchestra was set on stage level, it would be blocked by those elements. Therefore it was required to lift the orchestra. An impression of the scenic situation for “La Voix Humaine” is given in figure 1.

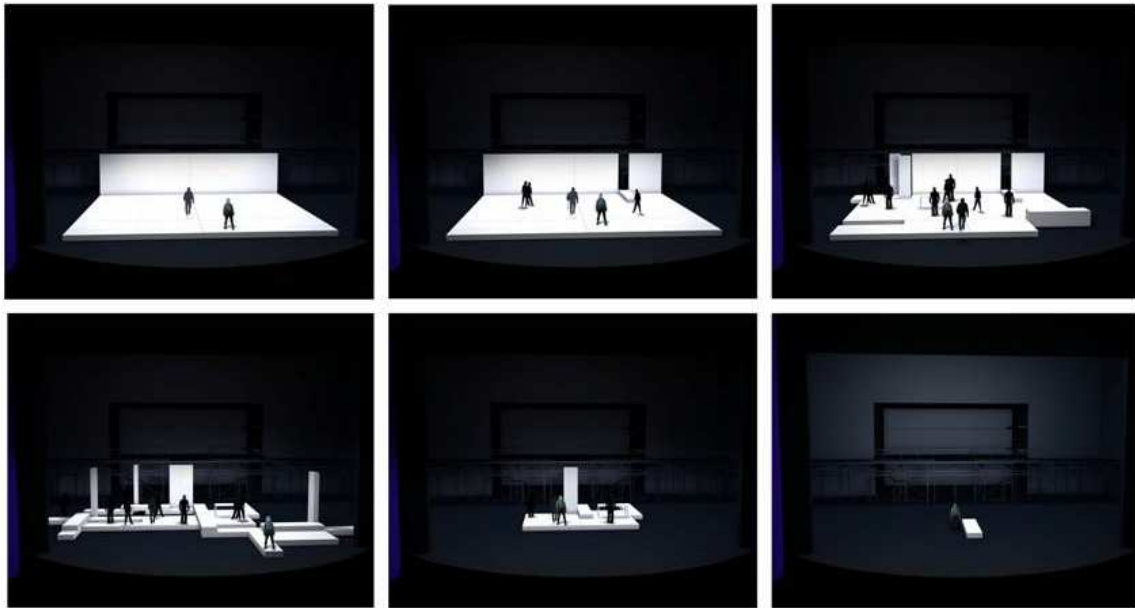

Figure 1: Scenic situation “La Voix Humaine”.

In figure 2 the plan and cross-section of the theatre is given with the orchestra set-up and the position of the scenic elements.

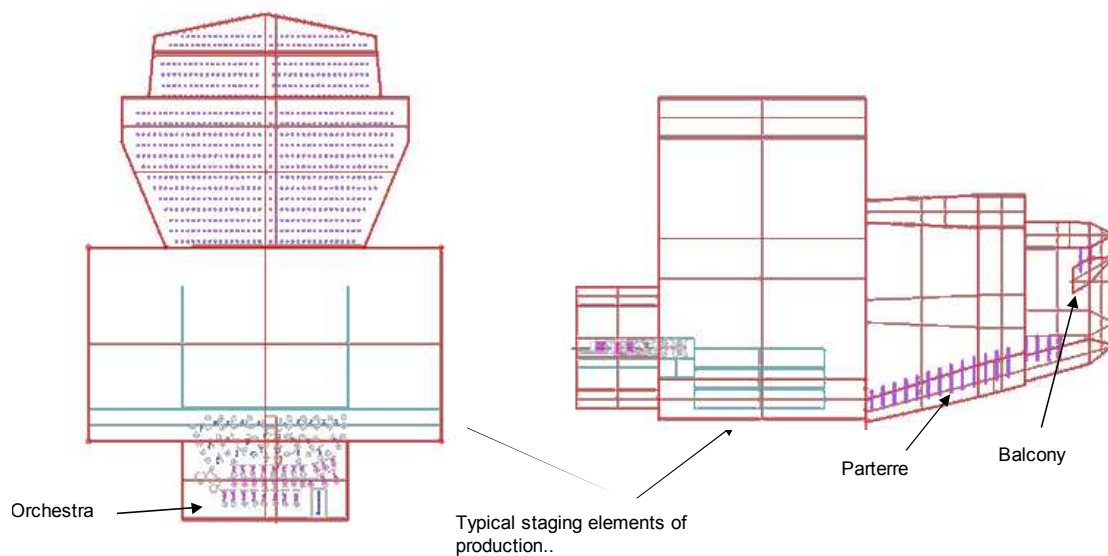

Figure 2: Plan and cross section of the theatre with the scenic set-up.

3. Architectural acoustical support

3.1 Reflectors to support the sound of the orchestra

As the orchestra was located at the backstage, the sound of the orchestra had to cross the stage towards the audience and had to be sufficiently clear and audible to the soloist on stage. To enable this, sound reflectors were proposed. The purpose of those reflectors was to create both reflections for the stage to support the soloist and for the hall to increase presence and level. In order to achieve those objectives, the following sound reflectors were proposed:

- a series of stretched reflectors above the orchestra;
- one specular right angle reflector at each side of the stage in the fly-tower.

The series of slightly curved stretched reflectors that were hung above the orchestra covered the entire width of the orchestra plateau, equal to the width of the backstage. The specular right angle reflectors covered the depth from approximately the plateau edge to approximately the proscenium opening.

3.2 Simulations to optimise the effectiveness of the reflectors

In order to determine the correct position and orientation for the reflectors so that the reflections were projected most efficiently, a simulation model had been made. In this model first order reflections were investigated for the stretched reflectors and first and second order reflections for the specular right angle reflectors. In figure 3 the propagation of the first order reflections is shown for the situation where the specular right angle reflectors are oriented straight (parallel to the stage centre line), in figure 4 the situation is shown with an angled oriented reflector.

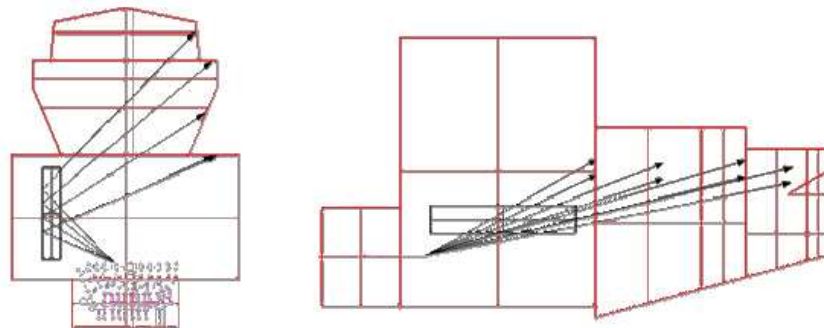

Figure 3: First order reflections with straight oriented specular right angle reflector.

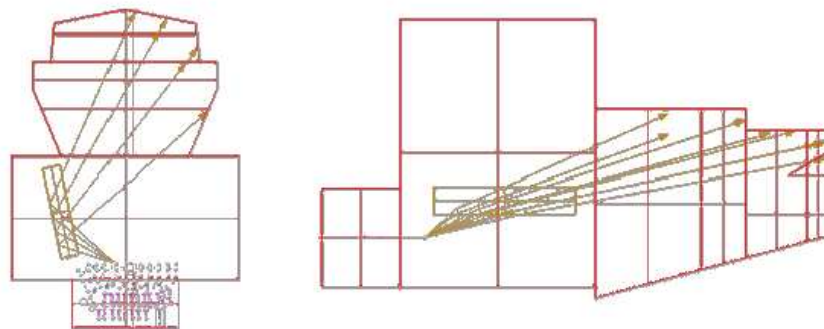

Figure 4: First order reflections with angled (in plan) specular right angle reflector.

The simulation shows better coverage is obtained when the reflectors are oriented at an angle; especially the balconies are covered better. In figure 5, 6 and 7 the coverage by the second order reflections is shown with the specular right angle reflector straight (figure 5 and 7 left) and angled (figure 6 and 7 right). The straight set-up causes reflections to be directed towards the stage and centre of the hall, but not towards the sides of the hall. The angled position (in plan) of the specular right angle reflectors will also provide reflections to the sides of the hall.

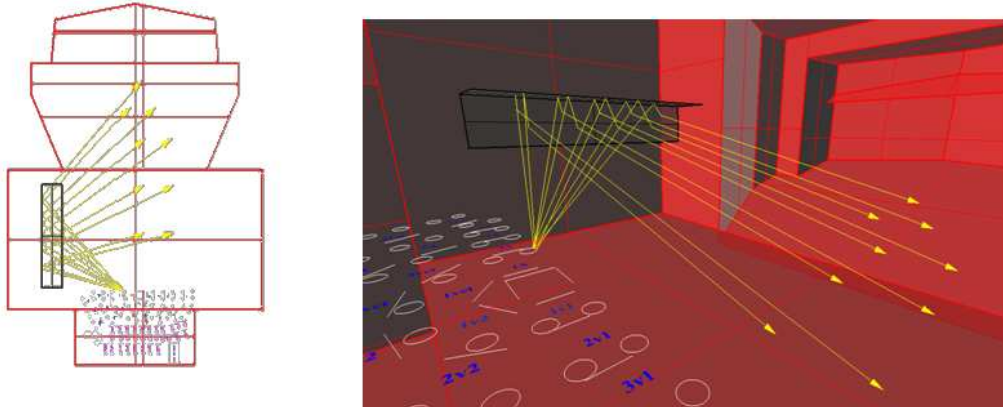

Figure 5: Second order reflections straight specular right angle reflector, with view from orchestra.

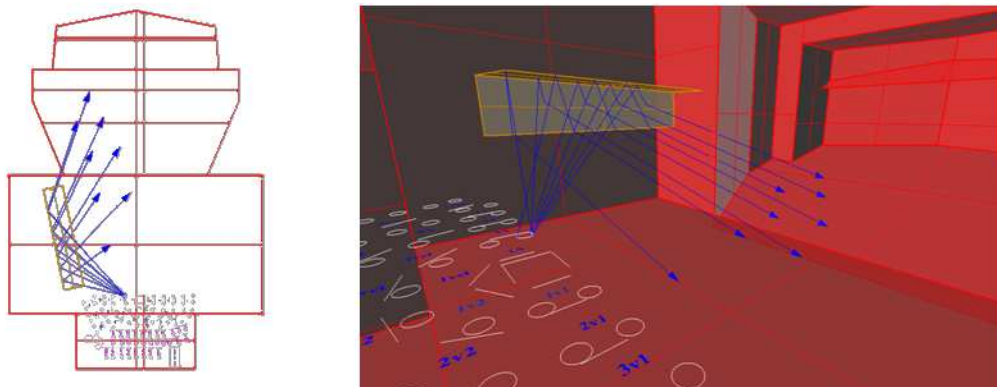

Figure 6: Second order reflections angled specular right angle reflector, with view from orchestra.

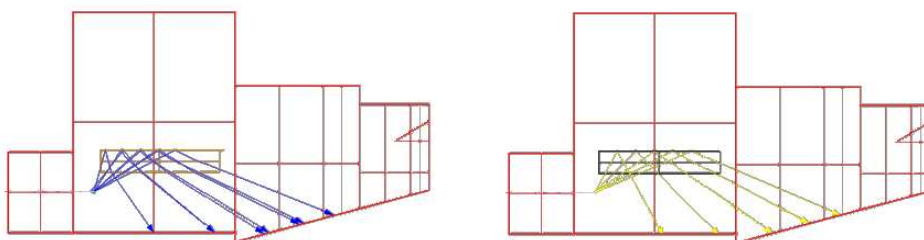

Figure 7: Section for angled (left) and straight (right) specular right angle reflector second order reflections.

In figure 8 the effect is shown of the first order reflections by the stretched reflectors above the orchestra.

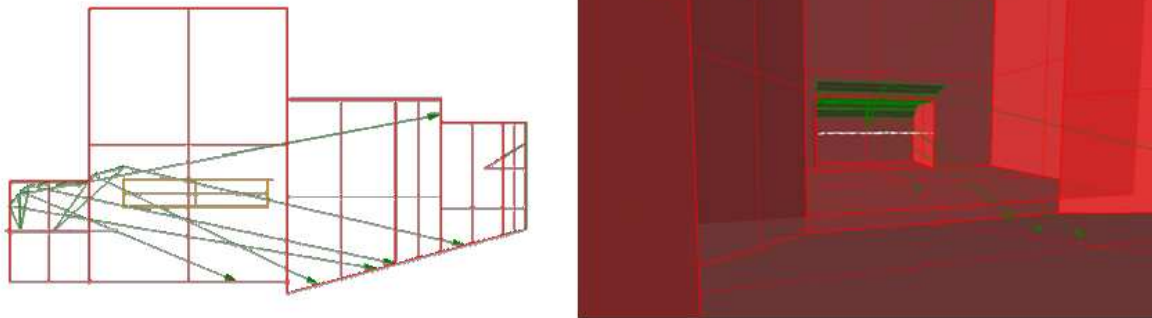

Figure 8: Reflectors above the orchestra with view from the hall; partial orchestra shell.

4. Electro-acoustical support

4.1 Increasing reverberation time and level

The hall, with a volume of approximately $5,000\text{m}^3$, was obviously acoustically too dry as it was a drama theatre. The reverberation time of the hall was approximately 1.0s in the mid-frequencies at a fully occupied situation. The reverberation time initially aimed for was determined as 1.4s in the fully occupied condition. This meant absorption had to be reduced, or “negative absorption” had to be added. A method to create such negative absorption is reverberation amplification by using multiple channel amplification [1]. According to [2], a single amplification channel is capable of increasing the reverberation time and energy density by 2%, however, experience has shown that 1.25% is a practical value. This implied that at least 32 multiple channels were required. It was decided to install a 40-channel system (those were already available as the system had been used in another theatre in Toulouse shortly before), meaning a 50% increase in reverberation time could be obtained. Loudspeakers were located on the side walls, on the parapet of the back balcony, in lighting openings of the back wall, under the ceiling on a truss and under the ceiling in front of the proscenium opening (see figure 9). The microphones were located under the ceiling. The patching between microphones and loudspeakers was done such that the majority of the channels were causing no pre-echo without additional delay.

4.2 Increasing the orchestra level

Since an electro-acoustical system was introduced, this also meant that the orchestra could be supported as it was expected to be potentially too low in level even with the reflectors on stage. Therefore, six cardioid microphones were located in front above the orchestra, mounted on a fly, aimed such that there was a preference for strings and flutes with respect to brass and percussion. In figure 9 the microphone positions are shown for the stage part of the system. The microphones were patched to loudspeakers located in front of the proscenium opening.

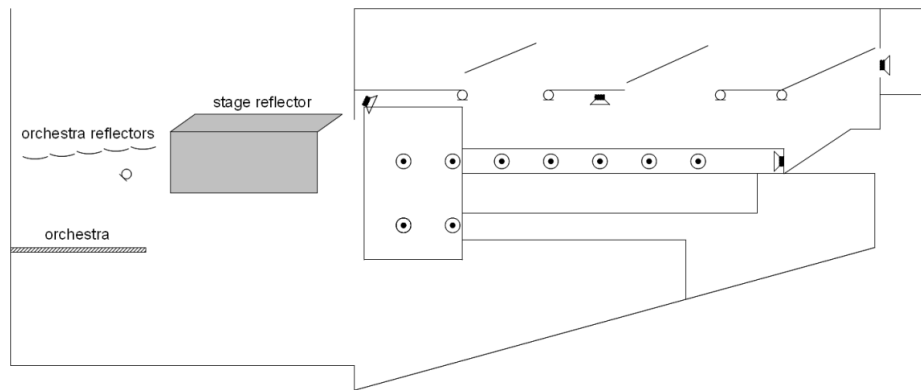

Figure 9: Microphone and loudspeaker positions.

It was decided to assign the microphone signals to available amplification channels in the hall. This could be done as little coupling between one of those microphones and any loudspeaker in the hall was expected, so the loop amplification of those channels was not significantly increased. In general for amplification the following equation applies:

$$g^2 = \mu^2 \beta^2 \quad (1)$$

The amplification is the ratio between the reproduced sound pressure and the sound pressure recorded by the microphone for which applies:

$$g^2 = \frac{p_{repro}^2}{p_{mic}^2} \quad (2)$$

If this is applied to the reverberant sound, g^2 [-] is the loop amplification, μ^2 [WPa⁻²] is the electrical transfer from squared sound pressure to sound power, β^2 [Pa²W⁻¹] the acoustical transfer from sound power to the squared sound pressure. Usually, β^2 is used in one enclosed room. If the amplification equation is used for coupled rooms, where the microphone is in one room and the loudspeaker is in the other, a correction needs to be made for the properties of both rooms and the coupling surface S_{couple} . Now the following applies:

$$\beta^2 = \beta_{total}^2 = \beta_{hall}^2 \frac{S_{couple}}{4\rho_0 c} \beta_{flytower}^2 \quad (3)$$

that can be simplified as:

$$\beta_{total}^2 = \beta_{hall}^2 \frac{S_{couple}}{A_{flytower}} \quad (4)$$

This is a first order approximation as the interaction between the two rooms is not taken into account, but it shows that - as $S_{couple}/A_{flytower}$ is usually smaller than 1 - the coupling between microphone and loudspeaker is less compared to when they are in the same room.

Although the microphones were assigned to existing amplification channels, individual control was required. This meant the system was configured such that the orchestra microphones had their own equalisation, level and mute control; the signal summation was done just before the system output. So, strictly speaking, the stage part acted as a separate multiple channel system. This was necessary as:

- individual volume control was required to balance the orchestra level apart from the acoustic correction of the hall;
- individual equalisation was required as the main system was meant for reverberation correction and the stage system needed a “flat” reproduction response;
- the orchestra microphones had to be switched off during “Pierrot Lunaire” and a few times for scenic reasons.

In figure 9 the block diagram of the system configuration is shown.

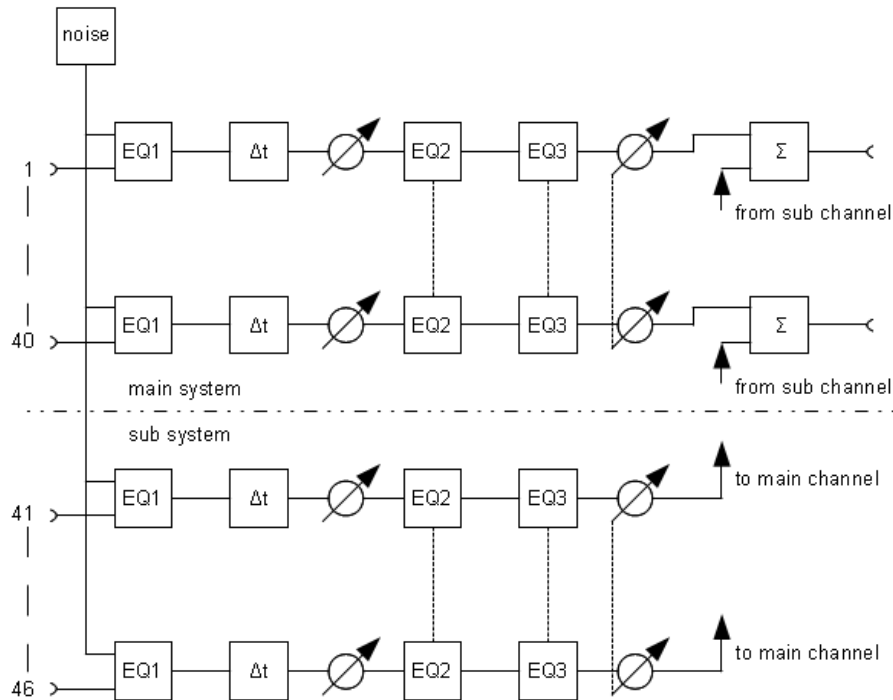

Figure 10: Block diagram of the multiple channel amplification system used at TNT.

4.3 Tuning procedure

If an (multiple channel) amplification system is used for reverberation amplification it should be tuned differently than when it is used for direct amplification. This can be explained by taking a closer look at figure 11, where all transmission paths are shown. Here the index “d” denotes the direct sound paths.

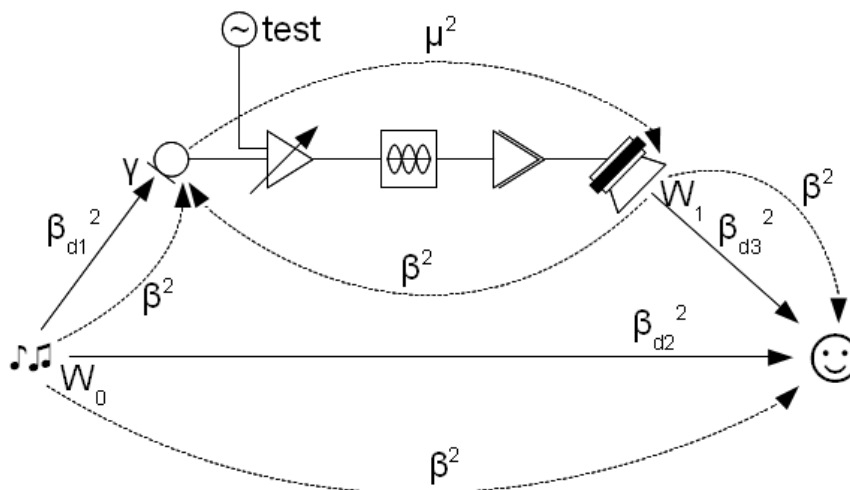

Figure 11: Overview of all paths when using an amplification system in a room.

The general equation for amplification is given by (1). μ^2 contains the random-incidence sensitivity of the microphone, which means when direct sound is amplified (free-field situation) a correction has to be made for the free-field sensitivity (on-axis). This means μ^2 has to be multiplied by the directivity factor. For the amplification of the direct sound applies:

$$g^2 = \gamma \mu^2 \beta^2 \quad (5)$$

where γ [-] is the directivity factor. This directivity factor is strongly frequency dependent especially for pressure-gradient microphones. Those microphones normally tend to have a “flat” free-field frequency response on-axis and near-axis and a “wild” random-incidence frequency response. Now, source W_0 will generate a sound pressure, having both direct and reverberant components, at the listener and at the microphone position. The reverberant paths may be considered equal, the direct paths differ. Loudspeaker W_1 will generate a sound pressure at the listener position, both direct and reverberant, and at the microphone position only the reverberant sound (the direct sound can be ignored). When source W_0 is amplified and the microphone frequency response on-axis is considered “flat”, the equaliser has to be adjusted (using the test source) in such a way as to compensate for the loudspeaker power response, β_{d3}^2 and β^2 in order to obtain a “flat” reproduction response at the listeners position. When the reverberation has to be corrected, the equalizer is adjusted such that in each band the required reverberation time is obtained. One of the functions of the equalizer is to cancel out the characteristics of all components involved, including the room. Actually, the equalizer is adjusted such that the required value for β^2 is obtained as β^2 contains the acoustic absorption (including the *negative* absorption); β^2 changes if μ^2 is altered. The equalizer setting for both situations differ. This means that if a classic tuning procedure is followed for reverberation amplification, where only a correction for the reverberation amplification is made, the tonal balance for direct sound amplification (in this case of the stage part) is disturbed. On the other hand, correcting for the direct sound may lead to an unwanted increase in reverberation time in certain frequency bands. To overcome this, the tuning procedure had to be adapted. It was executed such that the objective was to obtain a “flat” reproduction response for the stage part and that the disturbances that occur by this are corrected in the hall part. If both parts are simultaneously tuned in successive runs (the tuning procedure is an iterative process), the disruption of the hall part by the stage part will automatically be corrected. In each run the equaliser settings are adapted for the required correction until the objectives are obtained.

5. Two small experiments

5.1 Increasing spaciousness by increasing signal delay

An experiment was carried out by adding signal delay in order to determine if increased spaciousness could be perceived. The system was initially designed such that the first reflection from a loudspeaker originated “in time” for a natural wall reflection or ceiling reflection, depending on the loudspeaker position. An additional 20ms signal delay was introduced and an A/B comparison was done during a rehearsal. The perceived effect was an increased spaciousness (and increased room size) in the situation with the additional signal delay. In this particular situation the effect could be noticed as the walls themselves created weak reflections and so the “electro-acoustic” reflections became dominant. This setting was actually used during the performances. Further investigations need to be carried out to determine the effect of increased spaciousness by various delay times.

5.2 Increasing reverberation time by using loudspeakers in a coupled room

Another experiment was carried out by placing loudspeakers in a coupled room to determine whether an increase in reverberation time caused by the coupled room could be perceived, that is to say, an increase without an energetic increase. At the back of the balcony there were openings for follow-spot lights. Behind the openings there was a corridor with very little absorption. Four loudspeakers were placed in four of these openings. As an experiment they were faced towards the inside of the corridor. On the balcony an increased reverberation tail could be perceived. Further investigations have to be carried out in order to determine the effect more precisely, but results seem to indicate that pointing loudspeakers away from the audience and into a diffuse acoustic field can create perceptible positive effects. As a coupled room is involved, the tuning procedure has to be adapted when this kind of set-up is used.

6. Final tuning

The final tuning of the system was performed by critical listening during rehearsals and a final rehearsal with audience. This was done by the acousticians in close collaboration with the artistic management and the conductor's assistant. The objective was that it had to sound natural with sufficient intelligibility of the singer and an orchestra sound in balance with the singer.

7. Observations

The observation by everybody involved was that a result was perceived that sounded fully natural as if no amplification was involved. Remarks were made that it sounded better than in many opera house and that the orchestra was fully in balance with the singer, even with this rather unusual set-up with the musicians located behind the singer. The good acoustics were even noted in the French press, without the journalists being aware that an electro-acoustic system had been installed.

Conclusions

The performance in Toulouse showed that it is indeed possible to have the orchestra out of the pit and create opera house acoustics in a drama theatre at the same time. The quality obtained was beyond most people's expectation. The use of additional signal delay to obtain increased spaciousness and the use of multiple channel amplification in coupled rooms to increase the reverberation time needs to be further investigated.

Acknowledgements

The authors wish to thank Raphaël Bollen and Stijn Vermeiren of FACE (former AMPCO-Belgium) for their assistance in programming the system.

References

1. Cees Mulder, 2009, "New Parameters for Acoustic Absorption", 35th German Annual Conference on Acoustics (DAGA).
2. Cees Mulder, 2001, "Variable acoustics using Multiple Channel amplification of Reverberation", 17th International Congress on Acoustics.